

TOW AND COLLECT 1220

OWNER'S GUIDE & USER MANUAL

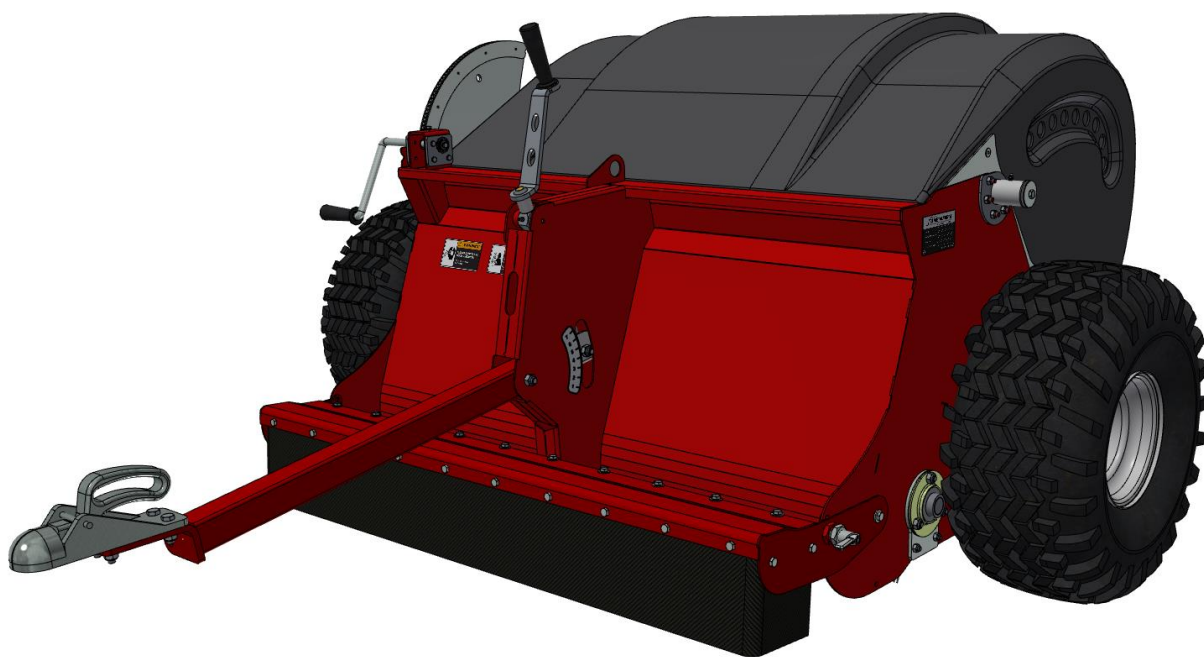

DISCLAIMER!

Read this Manual from start to finish before attempting to assemble, use or maintain the Equipment to which it refers. Do not attempt assembly, use or maintenance unless you know what you are doing. We accept no responsibility if you fail to follow the instructions in this Manual.

If you do not understand a point in this Manual, don't guess. Don't take short cuts. If in doubt, stop! Contact us or our authorised representatives for advice. We are here to help.

The Equipment is designed for easy assembly and use by persons who are reasonably familiar with farm implements and machinery. However, some of the maintenance procedures may require special tools or consumables or a level of experience with farm implements and machinery than you may not possess. If you encounter any difficulties, contact us or your own mechanic or technician for assistance.

To reduce packaging and freight costs, the drawbar is not attached to the Equipment. Assembly of the drawbar to the Equipment is your responsibility.

For each customer, operating conditions will vary, sometimes greatly. Such variations may affect the Equipment's performance. We have no control over your unique operating environment. Hence, we make no representations or warranties concerning the Equipment's performance under your actual operating conditions.

We made every effort to explain the assembly, operating, maintenance and safety procedures as clearly and completely as possible. Nonetheless, it is not possible to anticipate, nor address, every conceivable problem that may arise. This problem is compounded by the fact that no two operating environments are exactly the same. Therefore, we are not able to guarantee that this Manual will address every issue or problem that might arise concerning the assembly, operation, maintenance or safety of the Equipment to which it relates.

This Manual is intended to provide you with general guidance. For specific guidance and support, contact us or our authorised representative.

If you do not follow the assembly, use, maintenance and safety procedures in this Manual, the Equipment may not function as expected. More seriously, it may cause property damage, personal injury or other losses.

Use the Equipment at your own risk. We accept no liability for direct, indirect, incidental, special, or consequential damages resulting from your failure to follow the assembly, use, maintenance and safety procedures in this Manual. The foregoing limitation extends to damages for personal injury, damages to your vehicle and other property damage, whether suffered by you or by a third party.

We used all due care in preparing this Manual. However, we accept no liability for errors or omissions.

We reserve the right to change the design or specifications of the Equipment, or the information in this Manual, without notice.

Assembly, use and maintenance of the Equipment is entirely your risk and responsibility.

INTRODUCTION

Welcome

Metalform Tow and Farm takes this opportunity to welcome you as the new owner of a *Tow and Collect*. We want you to get the best results from your new Collector and this user manual will help you achieve this objective.

The safe operation and maintenance of your *Tow and Collect* is very important to prevent personal injury, damage to the machine, other property and the environment. We suggest you read and fully understand its coverage and your responsibilities of ownership prior to operating the machine or carrying out maintenance.

Best wishes and kind regards,

New Zealand

Metalform
74 Miller Street
Dannevirke, 4930
New Zealand
Phone: +64 6 374 7043
Email: sales@towandmow.co.nz
Web: www.towandmow.co.nz

Australia

Tow and Farm
105-117 Boundary Road
Laverton North, VIC 3026
Australia
Phone: 1300 630 279
Email: sales@towandmow.com.au
Web: www.towandmow.com.au

UK / Europe

Tow and Farm
Wood End
Prospect Road
New Farm Road Industrial Estate
Alresford
Hampshire, SO24 9QF
England
Phone: +44 1962 600 030
Email: sales@towandfarm.co.uk
Web: www.towandfarm.co.uk

USA / Canada

Tow and Collect
4051 Southmeadow Pkwy W.
Atlanta, GA 30349
USA
Phone: 877 778 7181
Email: sales@towandcollect.com
Web: www.towandcollect.com

INTRODUCTION

Notes about Safety

Your safety and the safety of others are very important. Using this machine safely is an important responsibility.

To help you make informed decisions about safety, we have provided operating procedures and other information in this manual. This information alerts you to potential dangers and hazards that could injure yourself or others.

You will find safety information in the following forms;

- **Safety Labels** – displayed on the machine.
- **Safety Messages** – preceded by a safety alert symbol  and one of these three signal words; DANGER, WARNING and CAUTION.
- **Safety Headings** – such as *IMPORTANT SAFETY INFORMATION*
- **Instructions** – how to use the machine correctly and safely.

This book is filled with safety information – please read it carefully!



WARNING!

Do not start, operate or service machine until you have read and understand the Owners Guide and User Manual.

Failure to do so could result in serious injury.

CONTENTS

SAFETY	6
WARRANTY	7
DELIVERY	8
Final Assembly	8
FEATURES & CONTROLS	10
Location of Features and Controls	10
Machine Height Adjustment	11
Tine Height Adjustment	11
Catcher Opening	12
Catcher Closing	12
OPERATION	13
Safe Operation Precautions	13
Before Operation	13
Using the Tow and Collect	14
Hints for Operation	14
Troubleshooting	15
SERVICING	16
The Importance of Maintenance	16
Maintenance Safety	16
Maintenance Schedule	17
Tyre Pressure	17
Lubrication	17
Chain Tensioning	19
Replacing the Canvas Skirt	20
Replacing the Brushes	21
Replacing the Tines	23
CONSUMER INFORMATION	24
Technical Information	24
Serial Number Location	24
Spare Parts List	25
Spare Parts Exploded View	29
Consumer Help and Information	30













SAFETY



Read and understand this owner's manual before operating this machine. Failure to do so could result in personal injury or equipment damage.

Know and understand the operation of all the controls. Never permit anyone to operate the machine without proper instructions.

WARNING!

-  NEVER allow any person to ride on the Tow and Collect.
-  NEVER use on slopes with an incline greater than 9° (1:5 gradient).
-  ENSURE you read and understand the owner's manual for the tow vehicle before operation.
-  KEEP children and pets away from area of operation.
-  ENSURE the tow hitch is in good repair and fit for towing. Ensure the tow ball on the tow vehicle is the correct size for the Tow and Collect.
-  Never allow any person to stand close to the machine when it is operating.
-  Where possible avoid operating in areas with rocks and loose debris as these can be flung out at speed and may also jam the brush spindle.
-  Eye protection and ear protection must be worn at all times.
-  Do not open catcher while moving.
-  Do not place hands or feet under the collector.
-  Never allow a person under the age of 18 years to operate the Tow and Collect.
-  Never use the Tow and Collect under the influence of alcohol or drugs.

WARRANTY

We warrant the Tow and Collect against defects in materials and workmanship. The term of this warranty is one year from date of purchase.

This is a parts only warranty. You are responsible for disassembling the defective part and reassembling the new part. We shall not be responsible or liable for the cost of field labour or other charges incurred by you in removing and/or reassembling any part.

This warranty is void in circumstances where: (a) The Tow and Collect has been misused, abused, neglected or damaged; (b) The Tow and Collect has been improperly assembled, repaired, serviced or maintained; (c) The Tow and Collect has been modified; (d) The Tow and Collect has been connected to other equipment with which it is not compatible; or (e) The Tow and Collect has been used for purposes other than for which it was designed.

To make a warranty claim, contact us at the address below. Describe the problem to us. We will tell you what to do next.

If we need to inspect, test or repair the part that is the subject of your claim, it is your responsibility to ship the part to us at your cost. If we accept your warranty claim, we shall either repair or replace the defective part in our discretion. We shall then ship the part back to you at our cost.

If the Tow and Collect is off-warranty or otherwise not subject to a valid warranty claim, we will repair or replace the Tow and Collect, or part thereof, at your cost

Our sole responsibility is to repair or replace a part that is subject to a valid warranty claim. Under no circumstance will we be liable for direct, indirect, incidental, special or consequential costs or damages to the maximum extent permitted by law. The foregoing disclaimer extends to damages for personal injury, damages to other equipment, other property damage, whether suffered by you or by a third party.

We accept no liability resulting from your failure to heed the assembly, use, maintenance and safety instructions in our Owner's Guide & User Manual.

This is an express warranty. We disclaim any other express or implied warranties, including warranties of merchant-ability or fitness for purpose, to the maximum extent permitted by law.

Some jurisdictions do not allow limitations or disclaimers of implied or statutory warranties. Some jurisdictions do not allow disclaimers or exclusions of consequential or incidental damages. Therefore, the above disclaimers, limitations and exclusions may not apply in all jurisdictions in which we sell the Tow and Collect.

This warranty gives you specific legal rights. You may have other rights or remedies pursuant to the laws in your territory. Nothing in this limited warranty should be construed as limiting or restricting any other statutory right or remedy that is available to you, except for such limitations or restrictions herein as may be allowed by the law of the territory.

DELIVERY

The Tow and Collect is delivered assembled, apart from the tow bar.
Before you complete the final assembly of the Tow and Collect, carefully check the entire machine for transit damage and report any problems immediately.

See the instructions below to complete the assembly of the Tow and Collect.
The tools required to attach the draw bar are included with your machine.

Final Assembly

To finish the assembly of the Tow and Collect, you must attach the tow bar to the main machine as described in the steps below.

Tools required;
13mm Spanner
16mm Spanner
17mm Spanner
18mm Spanner

What's in the box?

- Main Body (*fig 1*)
- Drawbar (*fig 2*)
- Bolts x 2 (M12 x 70)
- Nuts x 2 (M12 Nyloc)
- User Manual

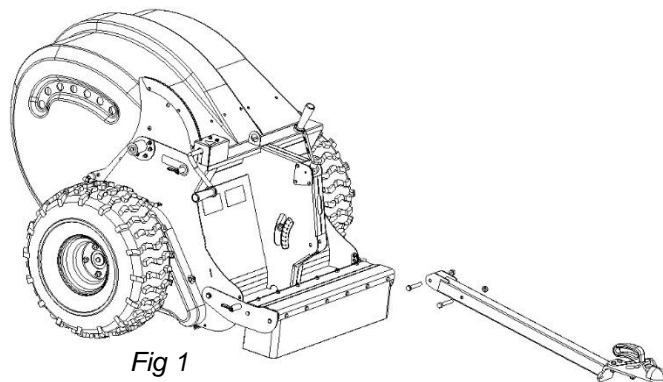

Fig 1

Fig 2

DELIVERY

Final Assembly (continued)

Step 1

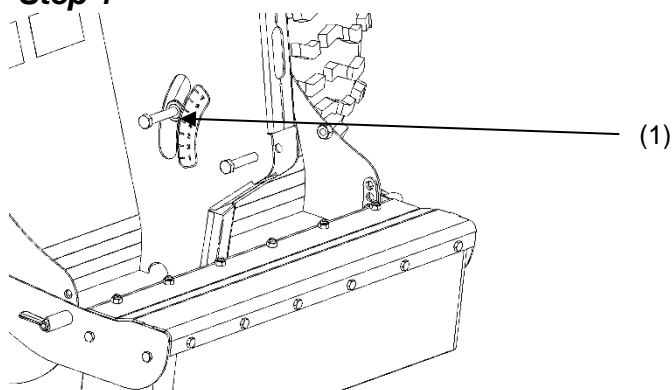

Remove bolts and nuts as shown in drawing on left. Put aside until required.

Note: When you remove the rear bolt, ensure the bush (1) is not removed from holder.

Step 2

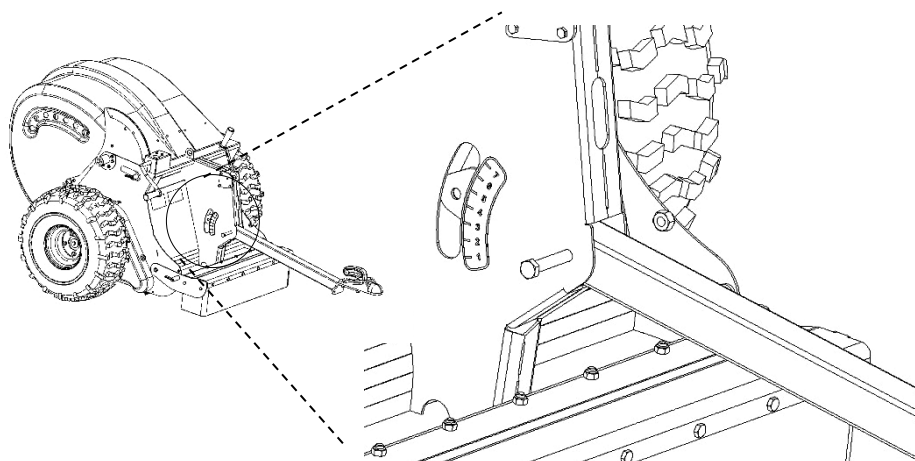

Insert drawbar into machine as shown on left.

Insert FRONT bolt and nut first.

Tighten bolt and nut until they just contact steel, and then do one half more turn.

Note: Do not do up so tight it that it wont pivot!

Step 3

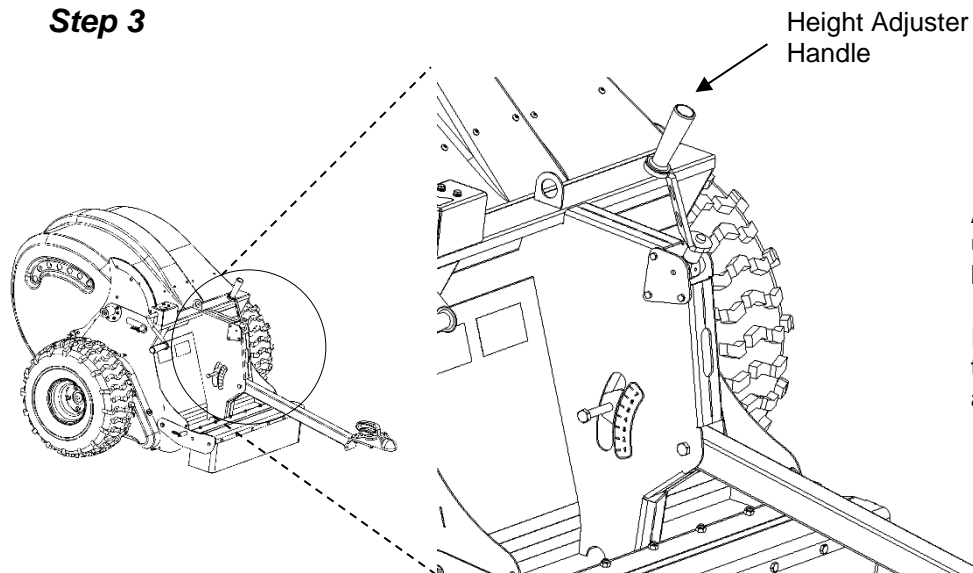

Adjust height adjuster handle until drawbar hole lines up with height adjuster bush.

Insert bolt and nyloc nut and tighten. This can be tightened to a reasonable limit.

FEATURES & CONTROLS

Location of Features and Controls

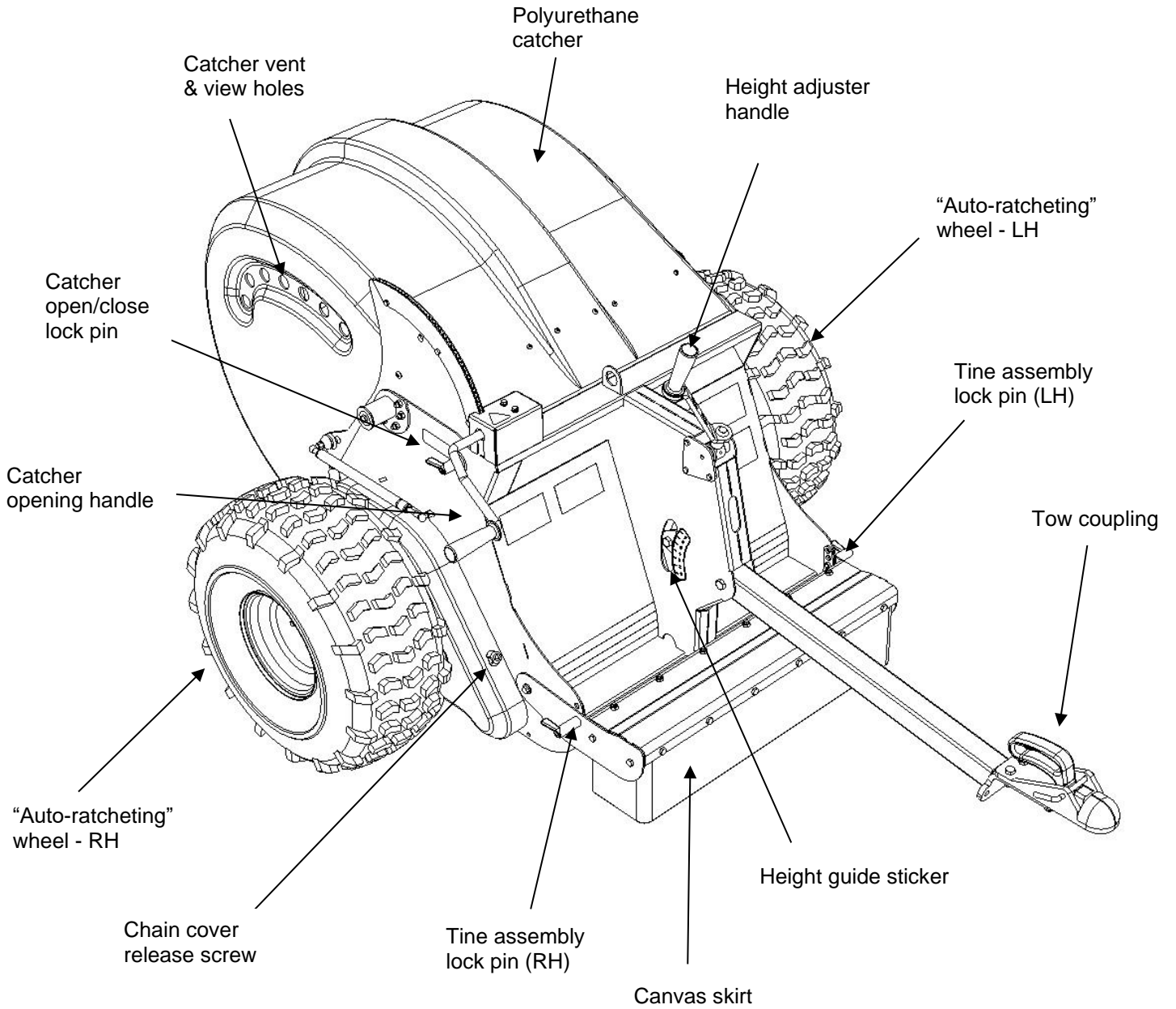

FEATURES & CONTROLS

Machine Height Adjustment

Height adjustment should only be done once the machine has been attached to the tow vehicle. This is because tow hitches vary in height.

- To **raise** the machine height, wind the height adjuster handle (1) in a clockwise direction. This will lift the brushes up.

- To **lower** the machine working height, wind the adjuster handle (1) in an anti-clockwise direction. This will lower the brushes down.

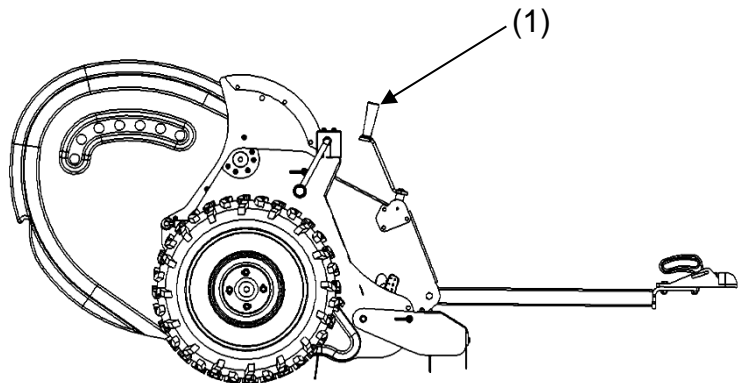

Tine Height Adjustment

The scouring tines on the front of the collector can be used when required, then adjusted out of the way when not required. Tines are useful for when picking up hard manure or if the grass is long. It breaks up the manure and makes it easier to pick up.

NOTE: Tine adjustment should only be done once the machine has been attached to the tow vehicle and the machine height has been set.

1. Rotate lock pin (2) to release, on one side of tine bar.
2. On the other side of the machine, support the weight of tine bar assembly and release other lock pin (2).
3. Position the tine assembly at desired height and rotate both lock pins (2) to secure the assembly.

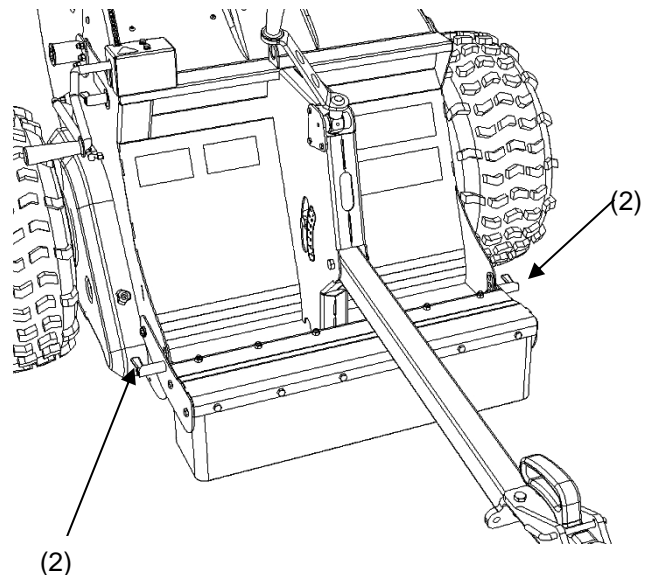

FEATURES & CONTROLS

Catcher Opening

Note: Do not over-fill the catcher!
If the catcher is over-filled it will be difficult to empty.

Warning: The catcher opening is assisted with a pressurised gas strut. Ensure the catcher handle (3) is held securely during entire opening process!

1. Hold catcher handle securely (3)
2. Rotate and pull lock pin (4) to release.
3. Carefully wind catcher opening handle (3) to lift open catcher.

Note: Use the lock pin (4) to hold the catcher open if necessary.

Suggested emptying procedure:

1. Reverse the Collector to a suitable dump site.
2. Open the catcher as described above
3. Move tow vehicle forward 1 metre (3 feet)
4. Close the catcher

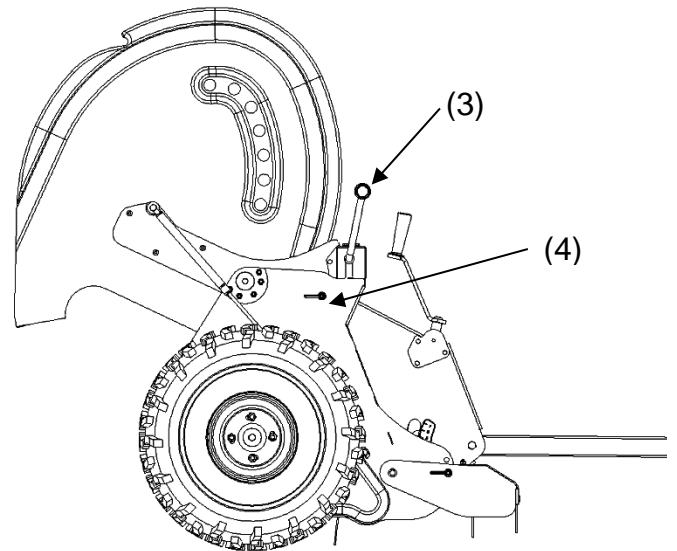

Catcher Closing

Warning: The catcher is assisted with a pressurised gas strut. Ensure the catcher handle (3) is held securely during entire closing process!

1. Securely hold the catcher handle (3), and rotate lock pin (4) to release.
2. Wind catcher handle (3) to close.
3. While still holding the catcher handle (3), rotate lock pin (4) to lock catcher closed.

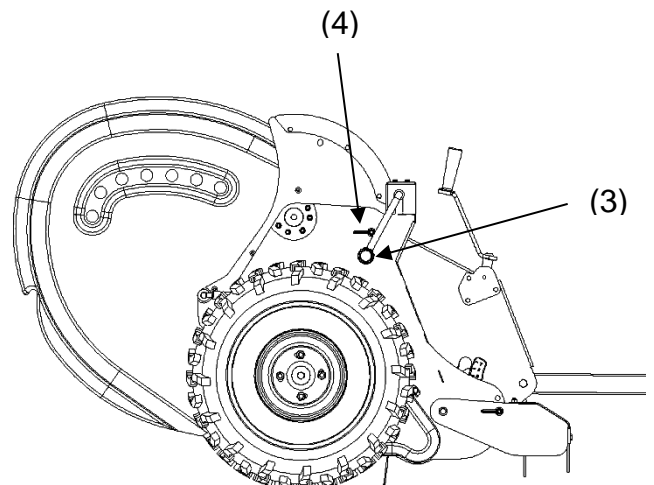

OPERATION

Safe Operation Precautions

Before operating machine for the first time, please review the important SAFETY information on page 5.

Before operating machine, read and understand the owners manual and safety precautions of the tow vehicle.

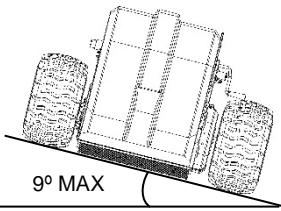
 DANGER!	
<p>DO NOT use on slopes with an incline greater than 9° (1:5 gradient)</p> <p>Exceeding this slope angle will cause the Tow and Collect and the tow vehicle to be unbalanced and may tip over causing death or serious injury.</p>	 <p>9° MAX</p>

Before Operation

- Ensure chain is lubricated (see *Maintenance Schedule* on page 17)
- Ensure the tow bar height is correctly set so that the body of the collector sits level to the ground (different tow vehicles have different tow ball heights, so it's important to set the Tow and Collect to the correct height.)
- Check that tyre pressure is in the range 5 – 7 psi (34 – 48 kPa). Check the condition of the tyres, look for signs of wear, cuts and impact damage. Ensure that the tyre pressure is the same in each wheel.
DO NOT over inflate tyres: If the pressure is too high the Tow and Collect will bounce on rough terrain, however if the pressure is too low, as the catcher fills the extra weight will compress the tyres and lower the effective brush height.

NOTE: Each wheel is fitted with an automatic ratcheting system so that the brushes only engage when the Tow and Collect is pulled forward.

OPERATION

Using the Tow and Collect

The Tow and Collect has been designed to reduce time collecting manure and provide healthier pastures for your horses.

1. Hitch the Tow and Collect onto your ATV, 4-wheeler or any other similar stable vehicle.
2. Set the height of the Tow and Collect - dependent on grass length and ground conditions
3. Drive around the paddock/field focusing on the areas requiring manure/debris pickup
4. Reverse the Tow and Collect to a suitable dumping site. Empty the catcher easily, with the gas strut assisted opening mechanism (as described in *Catcher Opening* on page 11)

See www.towandmow.com for videos and more information.

Hints for Operation

NOTE: Recommended tow vehicle capacity is 300cc or higher. Minimum is 250cc.

- Finding the perfect settings for your Tow and Collect largely depends on the current conditions of your pasture. So if you don't get it right the first time, don't be concerned.
- Using the Tow and Collect regularly improves the health of your pasture and animals. Regular pickups will also make the process easier by slowly removing all thatch and debris from the pasture.
- The first time you use your Tow and Collect, try driving in a 'grid' fashion (see image on right). This is so the approach on the pasture comes from all directions.

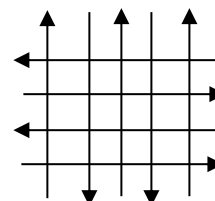

OPERATION

Troubleshooting

My Tow and Collect does not pick up the manure or debris!

- Ensure the brush height is set so the brushes are '*only just*' touching the ground.
- If the grass length is greater than 100mm (4"), cut grass first (suggested product is the Tow and Mow. see www.towandmow.com)
- Recommended travelling speed is 8-12 kph (5-8 mph).
- Check for brush wear. When the brushes slowly wear down, they become less efficient. Replace brushes when bristles get too short (see page 20).
- Check that inside the Tow and Collect is not jammed. Open catcher and clean chute.

The catcher is hard to empty

- Don't overfill catcher. If machine begins to perform badly, it may mean the catcher is full.
- If catcher is overfilled, the manure/debris will be too compacted, making it hard to empty.

The manure is too hard and dry to pick up

- When the manure is very dry, use the tines to lift the manure and break the seal on the ground.

The manure is too wet to pick up

- Lift tine assembly up and out of the way.

My Tow and Collect wheels keeps breaking traction

- Check that brush height is not too low making them difficult to rotate.
- Check there is no foreign objects or 'stringy' material caught around the brush shaft. Pay special attention to bearings at both ends.
- If the grass is too wet and/or long, you can try filling the wheels with 25% water.
- If grass is very wet, wait until grass is dryer and try again.

My Tow and Collect makes 'clicking noises' in reverse and during turns

- This is normal and the Tow and Collect has been designed to do this. The wheels use an automatic ratcheting system so that the brushes only engage when it is pulled forward.

My Tow and Collect pulls out grass or picks up too much dead grass

- Because it uses a rotating brush, it will pick up everything it can. The more you use it, the less dead grass there will be for it to collect.

SERVICING

The Importance of Maintenance

Good maintenance is essential for safe, economical and trouble-free operation.

To help you properly care for your Tow and Collect, the following pages include a maintenance schedule, routine inspection procedures, and simple maintenance procedures using basic hand tools. Other service tasks that are more difficult, or that require specific tools, should be carried out by a qualified service technician or qualified mechanic.

The maintenance schedule applies to normal operating conditions.

Maintenance Safety

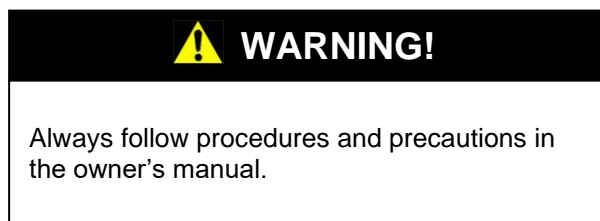

- Read the instructions before you begin and make sure you have the tools and the skills required.
- To reduce possibility of fire or explosion, be careful when working around gasoline. Use only a non-flammable solvent, NOT gasoline, to clean parts. Keep cigarettes, sparks and flames away from all fuel-related parts.

To ensure the best quality and reliability, use only new genuine Tow and Farm parts or their equivalent for repair and replacement.

SERVICING

Maintenance Schedule

Item	Each Use	Every month or 10 hrs	Every 3 months or 25 hrs	Every 6 months or 50 hrs	Every 12 months or 100 hrs	Refer to Page
Check Tyre Pressure			✓			17
Lubrication			✓			17
Check Chain Tension			✓			19
Canvas Skirt Replacement				✓		19
Brush Replacement					✓	21
Tine Replacement					✓	23

Perform at every indicated month or operating hour interval, whichever comes first.

Tyre Pressure

Check that tyre pressure is in the range 5 – 7 psi (34 – 48 kPa). Check the condition of the tyres, look for signs of wear, cuts and impact damage. Ensure that the tyre pressure is the same in each wheel.

DO NOT over inflate tyres; If the pressure is too high the Tow and Collect will bounce on rough terrain, however if the pressure is too low, as the catcher fills the extra weight will compress the tyres and lower the effective brush height.

Lubrication

Grease Nipples

There are 2 grease nipples that are located on the height adjuster assembly. See drawing on right for exact location.

Ensure they are lubricated (with Multi-Purpose grease or similar) each interval as per *Maintenance Schedule* to provide smooth operation and eliminate unnecessary wear on the height adjuster assembly.

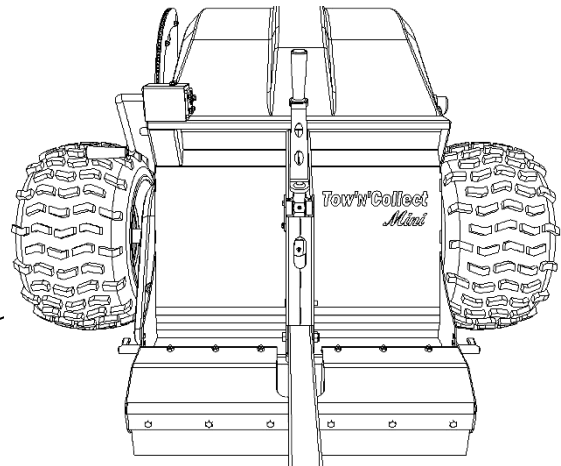
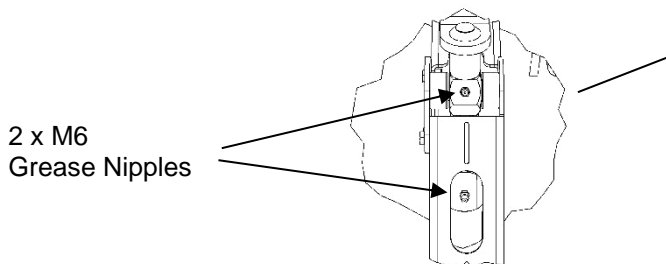

SERVICING

Lubrication Chain

The rotating brushes are ground driven off both wheels which is connected by a chain on the RH side of the Tow and Collect.

Ensure the chain is lubricated at each interval as per *Maintenance Schedule* on page 17.

CAUTION: Make sure the Tow and Collect is disconnected from the tow vehicle before attempting to remove Chain Cover (step 1).

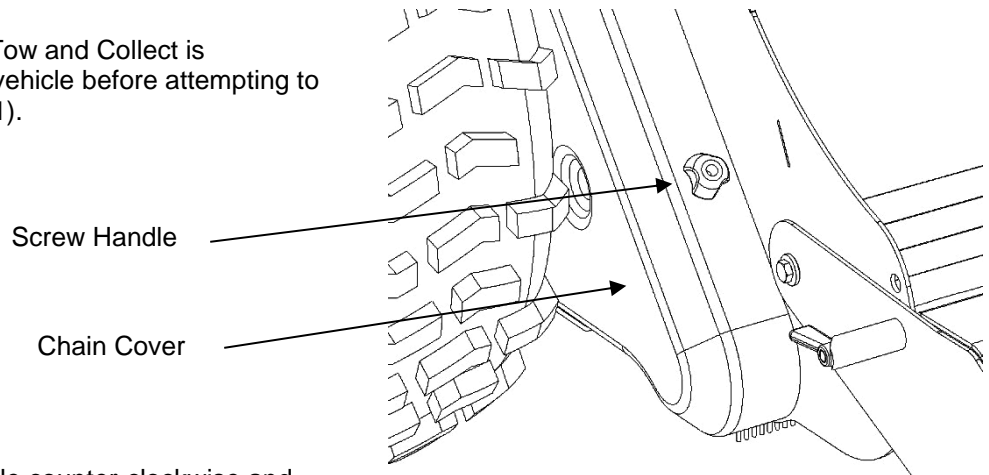

1. Loosen screw handle counter-clockwise and remove with fingers.
2. Slide Chain Cover forward and out.
3. Hold chain lube can 200mm (8") away from chain and spray onto chain where visible.
NOTE: Use chain lube spray or equivalent.
4. Move Tow and Collect FORWARD 600mm (25") and repeat step 3.
CAUTION: Ensure no loose clothing or other persons are near the Tow and Collect whilst moving forward.
5. Replace cover and tighten screw handle.

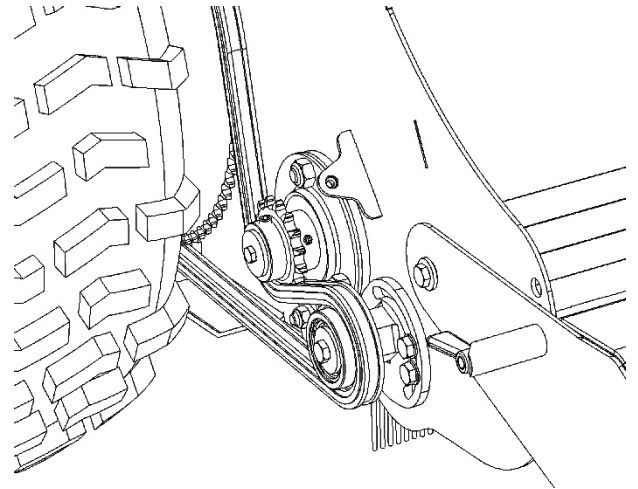

SERVICING

Chain Tensioning

NOTE: The following task is recommended to be carried out by a qualified service technician or qualified mechanic.

Ensure chain tension is checked each at interval as per *Maintenance Schedule* on page 17.

1. Loosen screw handle counter-clockwise and remove.
2. Slide Chain Cover forward and out.

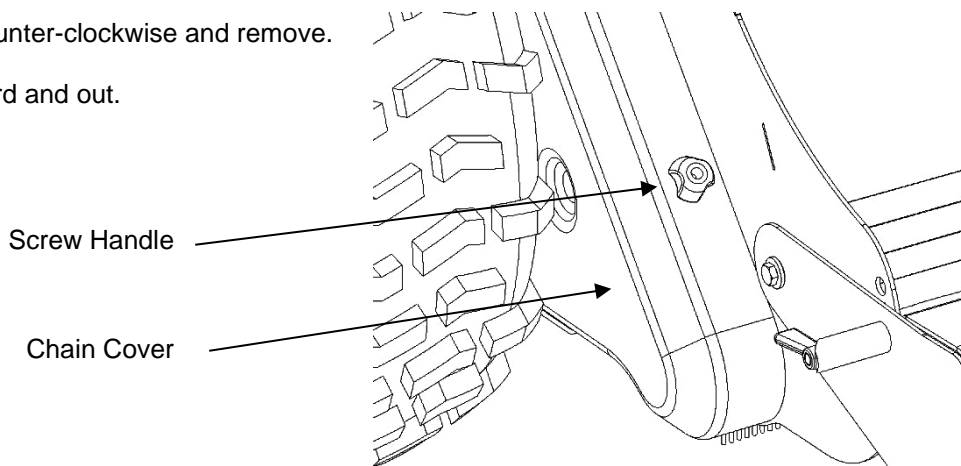

3. Loosen both M8 Lock Bolts with supplied spanner (loosen only – do not remove!)
4. Using the 32mm supplied spanner, fit to top of Hex Shaft on chain tensioner and apply force clockwise.
5. While maintaining force on tensioner assembly, tighten up one M8 Bolt.
6. Tighten other M8 Bolt.
7. Replace cover and tighten screw handle.

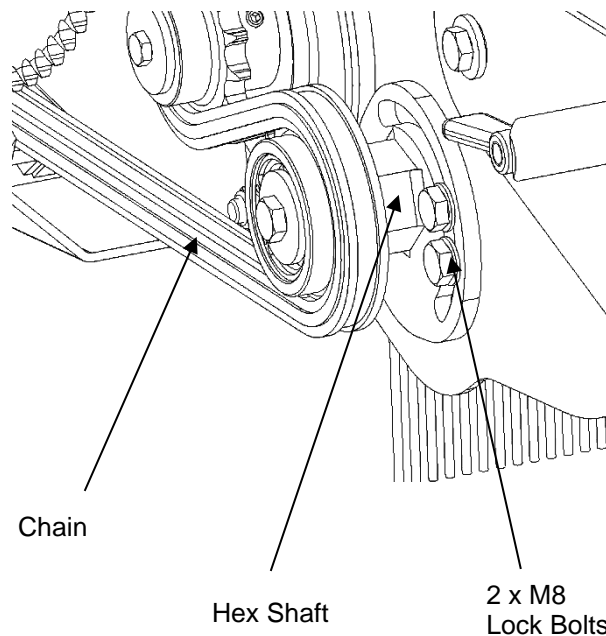

SERVICING

Replacing the Canvas Skirt

NOTE: The following task requires special tools (not supplied) and is recommended to be carried out by a qualified service technician or qualified mechanic.

Ensure canvas skirt is changed at each interval as per *Maintenance Schedule* on page 17.

The Canvas Skirt is shown on the machine in the diagram on the right.

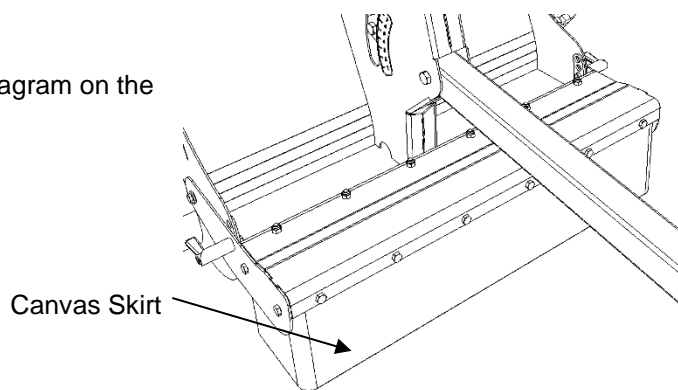

1. Remove Canvas Skirt by loosening and removing 6 x M8 Bolts and Nuts.
2. Replace Canvas Skirt
3. Tighten all bolts.

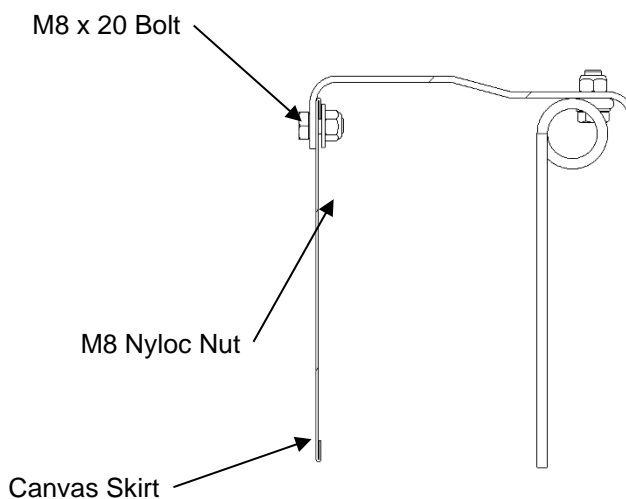

*Cross-section view
of Canvas Skirt and
mounting position.*

SERVICING

Replacing the Brushes

NOTE: The following task requires special tools (not supplied) and is recommended to be carried out by a qualified service technician or qualified mechanic.

Ensure brushes are changed at each interval as per *Maintenance Schedule* on page 17.

To gain easy work access to the underneath of the machine, remove the catcher as described in the following steps.

- **Remove the Catcher**

1. Open the Catcher and ensure it is locked open (as per instructions on page 11)
2. Remove gas strut clips (5) so gas strut (6) can be removed completely.
3. Loosen and remove centre bolt (7) on RH catcher pivot (8)

CAUTION: You will need extra assistance to support the weight of the catcher as you do the next 2 steps.

4. Loosen and remove 5 x Nuts from catcher mount bracket on RH side and 5 x Nuts from catcher mount bracket on LH side.
5. Remove both catcher mount brackets by sliding out, and remove catcher from machine.

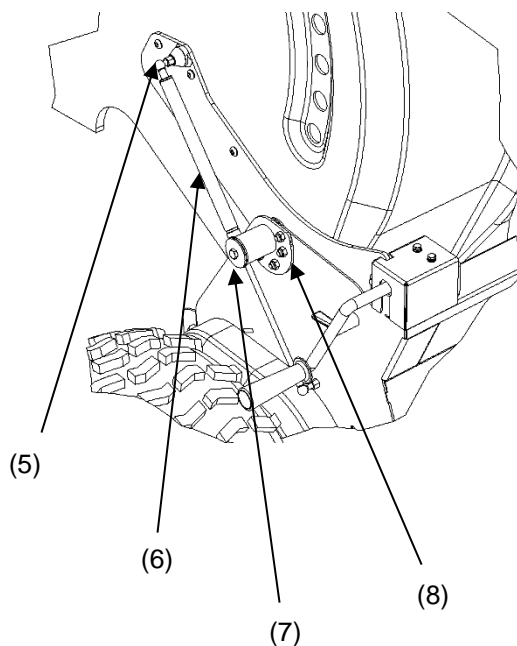
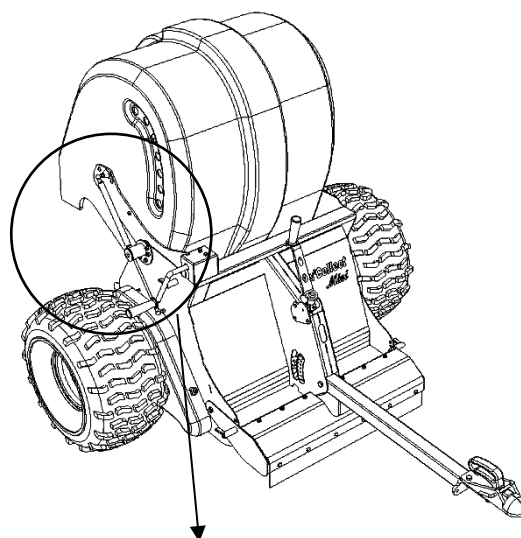

SERVICING

Replacing the Brushes (continued)

- **Remove the Brushes**

WARNING: You will need extra assistance to do the following steps.

6. Place the machine on its back edge (see *fig 3*) so you have easy access to the brush assembly.
CAUTION: Ensure the machine is securely held in position to eliminate ANY chance of it falling over while carrying out the following task
7. Loosen and remove 6 x Nyloc Nuts (9) that hold the brush clamp (10) in position.
(see *fig 4*)
8. Repeat for 4 x brushes.
9. Fit new brushes, ensuring that each brush is pushed back hard against the threaded studs along the entire length of the brush before the nuts are tightened.
10. Tighten all nuts to a torque of 9 Nm (7 ft-lb).
11. Rotate brush assembly slowly by hand and check that brushes do not rub on the Tow and Collect chassis.

NOTE: If the brushes are replaced more than 3 times also replace the Nyloc Nuts (as the locking ability of the nuts will be reduced from loosening and tightening multiple times)

- **Re-Assemble**

12. Unsecure machine and lower back onto the wheels and drawbar onto the ground.
13. Assemble catcher onto machine as described in steps 5 – 1.

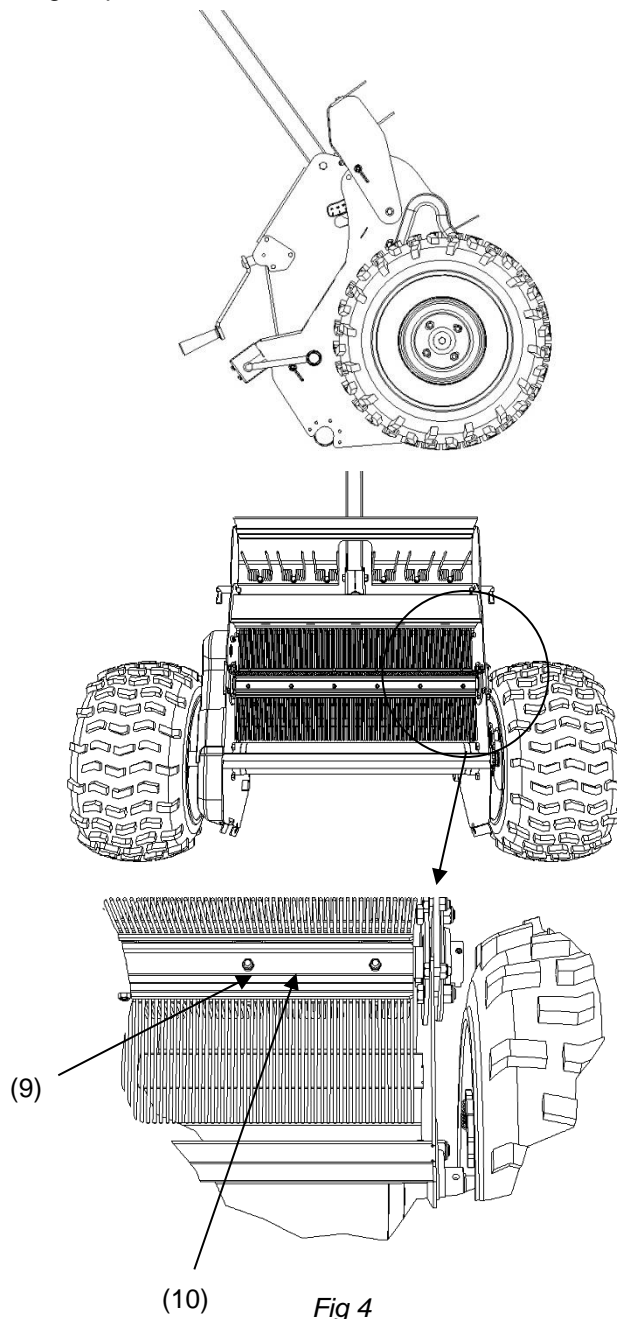

SERVICING

Replacing the Tines

NOTE: The following task requires special tools (not supplied) and is recommended to be carried out by a qualified service technician or qualified mechanic.

1. Lock tine bar assembly into upper most position (shown in *fig 5*)
2. Loosen and remove bolt and nut on each tine.
3. Replace Tine by inserting the bolt through the U-shaped part of the tine and onto the frame.
Note: Ensure Tine is positioned in the correct orientation (as shown in *Fig 6*)

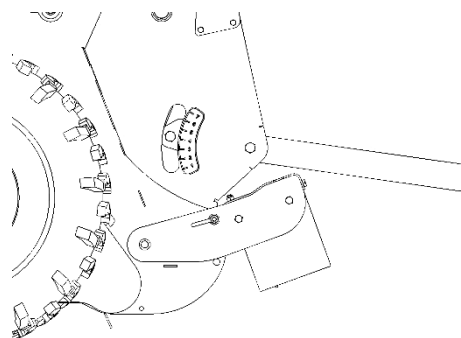

Fig 5

4. Replace nut onto the top side of the assembly.
5. Tighten all nuts to a torque of 15 Nm (11 ft-lb).

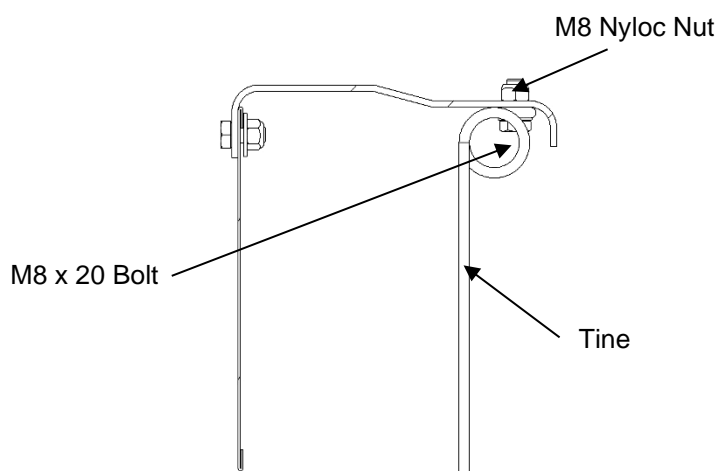

Fig 6

CONSUMER INFORMATION

Technical Information

Model	Tow and Collect 1220	
Manufactured By	Metalform (Dannevirke) Ltd	
Collection Width	1220 mm	48"
Overall Width	1460 mm	77"
Height	960 mm	38"
Length - excluding tow bar - including tow bar	1365 mm 2160 mm	54" (4' 6") 85" (7' 1")
Weight - net - gross	165 kg 210 kg	365 lbs 460 lbs
Catcher Capacity	500 Litres	130 US Gallons
Brushes	Replaceable Nylon Brushes (4 x)	
Tow Hitch Options	1 7/8" OR 50mm Tow Coupling OR 23mm Ø thru hole	

Serial Number Location

You will find the serial number etched onto an aluminium tag which has been applied to the LH side of the Tow and Collect, by the manufacturer. (See fig 7)

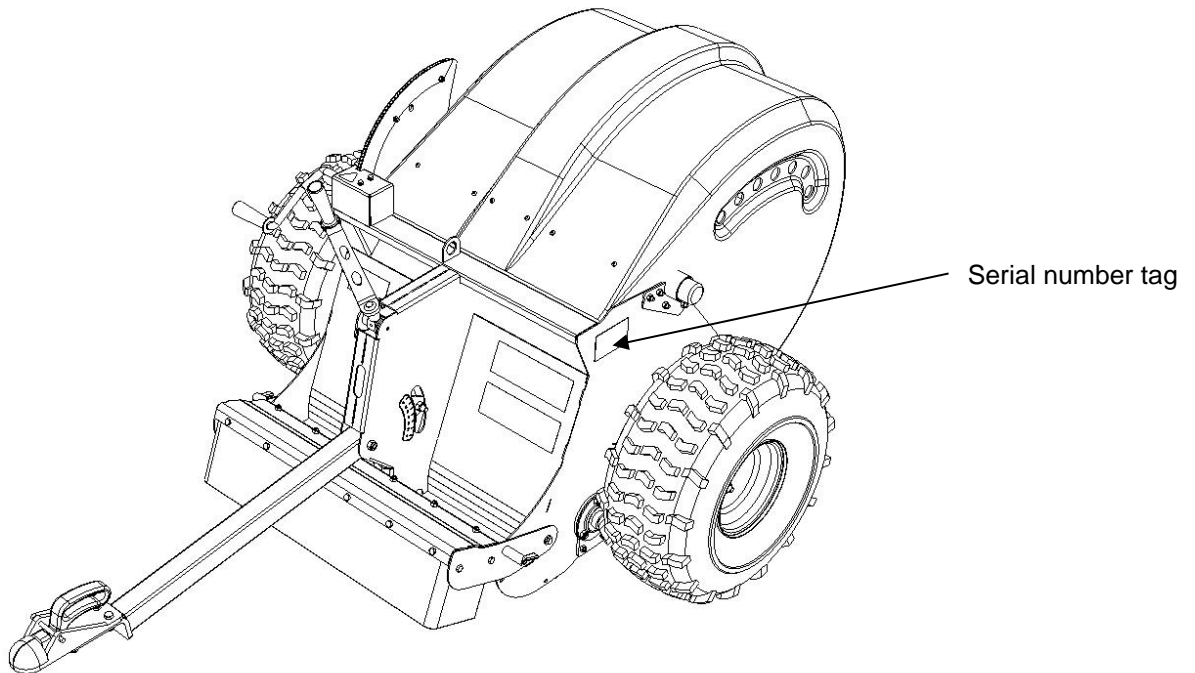

CONSUMER INFORMATION



Spare Parts List

NOTE: For reference purposes only. Part descriptions and/or part numbers subject to change without notice

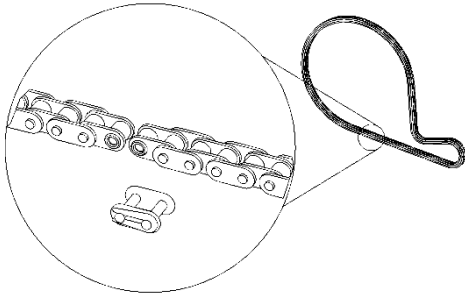
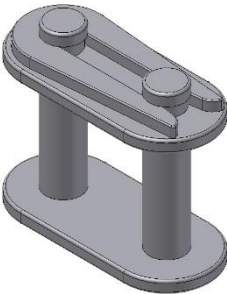
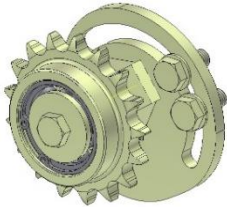

- For more information about each spare part pack, see www.towandmow.com.
- During any correspondence with Tow and Farm, ensure you have the following information handy:
 - Model and serial number
 - Date of purchase
 - Your name and address
 - Detailed description of the problem

Description	Part Number	Image	Ref (pg)
Bearing - Brush Shaft <i>Bearing Ø15mm 2 x Grub Screws</i>	YAR2062RF		<i>location on machine page 29 item 1</i>
Bearing - Wheel <i>Bearing Ø20mm 2 x Grub Screws</i>	YAR2082RF		<i>location on machine page 29 item 2</i>
Brushes – Set of 4 <i>4 x Nylon Brushes 24 x Nyloc Nuts</i>	TOCO_1220_A020		<i>fitting instr. Page 22</i> <i>location on machine page 29 item 4</i>
Catcher Handle Kit <i>Formed Handle</i>	TOCO-A01-009		<i>location on machine item 5</i>

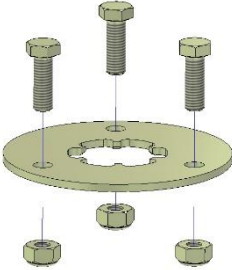
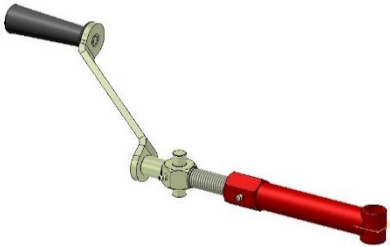

Spare Parts List (continued)

Description	Part Number	Image	Ref (pg)
<p>Catcher Handle Kit <i>Formed Handle</i></p>	<p>TOCO-A01-009</p>		<p><i>location on machine item 5</i></p>
<p>Chain Kit <i>1/2" Pitch Chain (63 Links)</i> <i>Chain Link</i></p>	<p>TOCO_M702_P331</p>		<p><i>fitting instr. page 19</i> <i>location on machine page 29 item 6</i></p>
<p>Chain Link Only <i>1/2" Pitch Chain Link</i></p>	<p>08BL-RJ</p>		<p><i>fitting instr. page 19</i> <i>location on machine page 29 item 7</i></p>
<p>Chain Tensioner <i>Complete Tensioner Assembly</i> <i>2 x Bolts and Washers</i></p>	<p>TOCO_M702_A261</p>		<p><i>fitting instr. page 19</i> <i>location on machine page 29 item 8</i></p>
<p>Gas Strut <i>Gas Strut</i> <i>2 x Clips</i></p>	<p>C10-210500-1000N</p>		<p><i>fitting instr. page 21</i> <i>location on machine page 29 item 9</i></p>

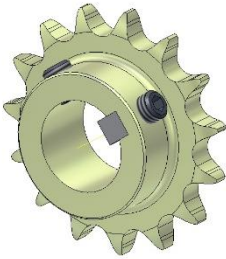
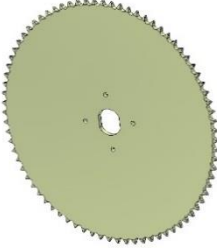
Spare Parts List (continued)

Description	Part Number	Image	Ref (pg)
<p>Grass Cutter Kit</p> <p>1 x Cutting Plate 3 x Bolts and Nuts</p>	<p>TOCO_M700_A67</p>		<p>location on machine page 29 item 10</p>
<p>Height Adjuster Handle Kit</p> <p>Complete Assembly</p>	<p>TOCO_M702_A249</p>		<p>location on machine page 29 item 11</p>
<p>Canvas Skirt Kit</p> <p>1 x Canvas Strip</p>	<p>TOCO_1220_P482</p>		<p>fitting instr. page 20</p> <p>location on machine page 29 item 12</p>
<p>Sprocket - Brush Shaft</p> <p>1 x Sprocket 1 x Key Steel 2 x Grub Screws</p>	<p>TOCO_M702_A259</p>		<p>location on machine page 29 item 13</p>
<p>Sprocket - Drive Wheel</p> <p>1 x Sprocket</p>	<p>TOCO_M702_P318</p>		<p>location on machine page 29 item 14</p>

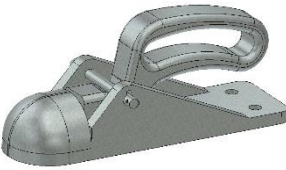
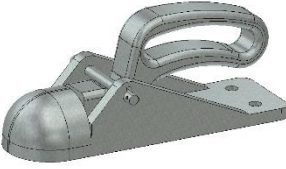
Spare Parts List (continued)

Description	Part Number	Image	Ref (pg)
<p>Tine Kit</p> <p>1 x Tine 1 x Bolt 1 x Washer 1 x Nyloc Nut</p>	<p>TOCO-A01-100</p>		<p><i>fitting instr.</i> page 20</p> <p><i>location on machine</i> page 29 item 16</p>
<p>Tow Coupling 1 7/8"</p> <p>1 x Coupling</p>	<p>99590</p>		<p><i>location on machine</i> page 29 item 17</p>
<p>Tow Coupling 50mm</p> <p>1 x Coupling</p>	<p>R93963</p>		<p><i>location on machine</i> page 29 item 18</p>
<p>Tyre and Wheel Kit</p> <p>1 x Tyre and Wheel</p>	<p>9549</p>		<p><i>location on machine</i> page 29 item 19</p>

Spare Parts Exploded View

Refer to Spare parts Lists on pages 25-28 for Part Numbers and Descriptions

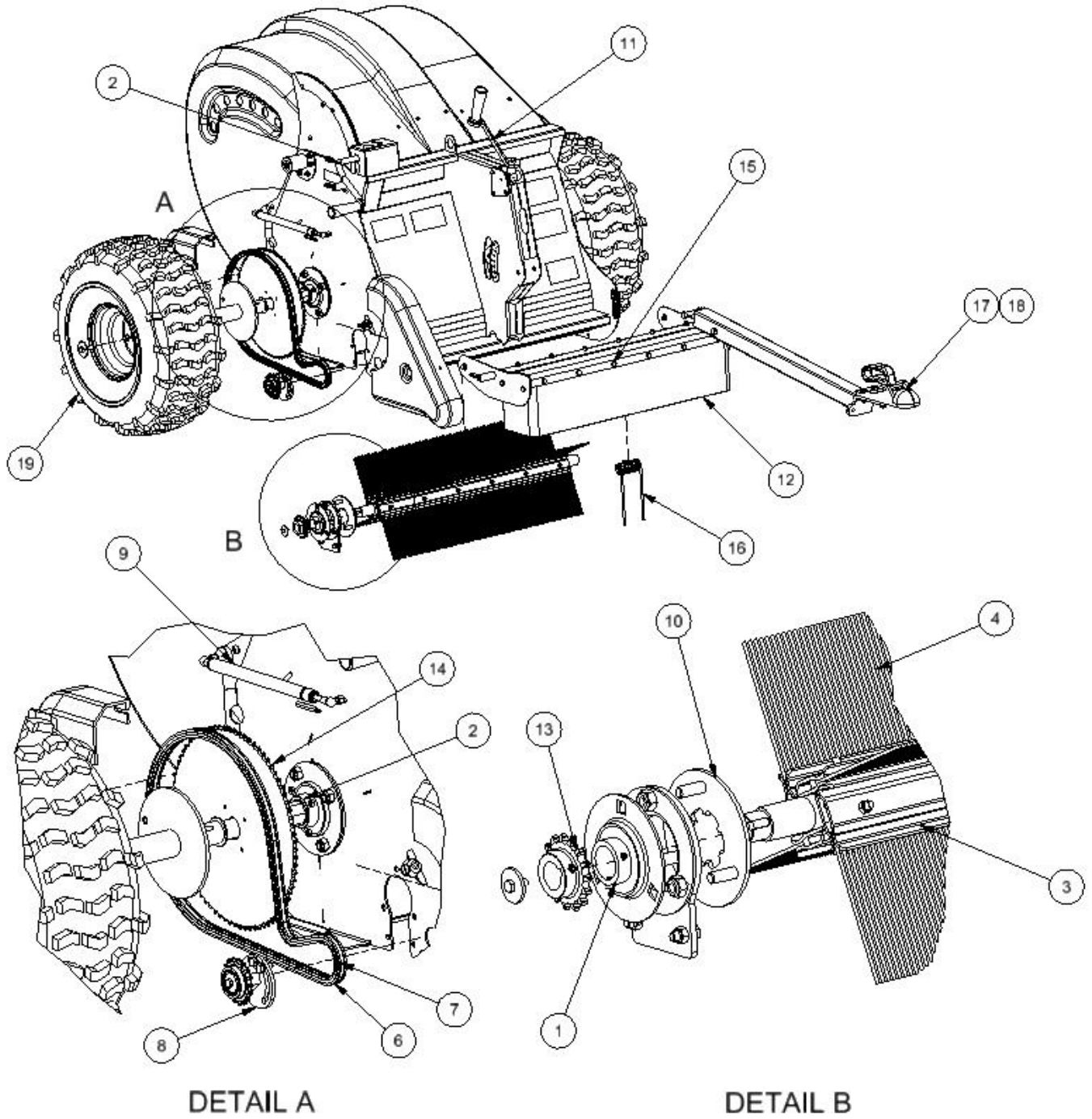

CONSUMER INFORMATION

Consumer Help and Information

For more help on your Tow and Collect product, please contact your local distributor.
Contact details are found at www.towandmow.com

If you are dissatisfied with any part of the Tow and Collect product or service, we welcome your comments and feedback.

You can write to Head Office: Metalform
74 Miller Street
Dannevirke, 4930
New Zealand

Email: support@towandmow.co.nz

Or Phone: +64 6 374 7043

When you write or call, please give us the following information:

- Model and serial number
- Date of purchase
- Your name and address
- Detailed description of the problem

New Zealand

Metalform
74 Miller Street
Dannevirke, 4930
New Zealand
Phone: +64 6 374 7043
Email: sales@towandmow.co.nz
Web: www.towandmow.co.nz

Australia

Tow and Farm
105-117 Boundary Road
Laverton North, VIC 3026
Australia
Phone: 1300 630 279
Email: sales@towandmow.com.au
Web: www.towandmow.com.au

UK / Europe

Tow and Farm
Wood End
Prospect Road
New Farm Road Industrial Estate
Alresford
Hampshire, SO24 9QF
England
Phone: +44 1962 600 030
Email: sales@towandfarm.co.uk
Web: www.towandfarm.co.uk

USA / Canada

Tow and Collect
4051 Southmeadow Pkwy W.
Atlanta, GA 30349
USA
Phone: 877 778 7181
Email: sales@towandcollect.com
Web: www.towandcollect.com